

Thermostatic Steam Traps (continued)

Series 9C Balanced Pressure **BEAR TRAP**

The Series 9C are for institutional and commercial heating system applications or others that require high capacity operation.

- Subcooling for extremely efficient system operation and elimination of flash steam losses on low pressure systems.
- Sizes available:
 - 1" NPT Angle
- Replaceable Dura-Stat® module
- 3-Year Warranty
- Meets Mil specification WW-T-696-E Type V, Style A, Class 1 - 4
- Stainless steel components
- Resistant to moderate water hammer and chemical attack
- Maximum operating pressure 125 psig (8.6 bar)

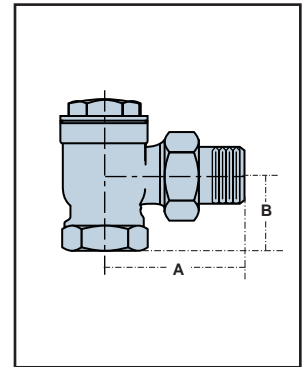

Dimensions, in. (mm)

Model	Pattern	Size	A	B
9C	Angle	1	3 ⁷ / ₃₂ (82)	1 ³ / ₄ (45)

Ordering Information

Model Number	Size in.	NPT Part Number	Differential Pressure Rating psi (bar)	Weight lbs. (kg)
9C-4A-125 Angle	1	402005	125 (8.6)	2.3 (1)

Gross Ratings

Series	Differential Across Trap psi (bar)											
	¼ (.017)	½ (.034)	1 (.069)	1½ (.10)	2 (.14)	5 (.35)	10 (.7)	15 (1.0)	25 (1.7)	50 (3.5)	100 (6.9)	125 (8.6)
9C	Capacity lbs./hr (kg/hr)											
	110 (50)	150 (68)	210 (95)	255 (116)	300 (136)	480 (218)	760 (345)	950 (431)	1350 (612)	2100 (953)	3500 (1590)	4200 (1905)