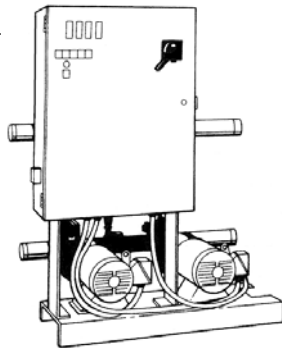

JOB: UNIT TAG: ENGINEER: CONTRACTOR:	REPRESENTATIVE: ORDER NO.: SUBMITTED BY: APPROVED BY:	DATE: DATE: DATE:
---	--	--

 SHOWN WITH
OPTIONAL PANEL

2 Pump 70E Series Pressure Booster System

DESIGN DATA:	Maximum System Capacity Required: _____ GPM Pressure Required at Discharge Header: _____ PSI Minimum Suction Pressure to Suction Header: _____ PSI Pressure Drop through Package and PRV's: _____ PSI Required Boost Developed by 70E _____ PSI Header Size _____ IN.	
---------------------	--	--

	Pump No. 1	Pump No. 2
PUMP DATA:		
Gallons per Minute	_____	_____
TDH*	_____	_____
PRV	_____	_____
Series <u>1531</u>	Size _____	Size _____
Motor HP	_____	_____
Motor RPM _____	Voltage _____	Hertz _____
		Phase _____

*Note: TDH includes PRV and package losses.

STANDARD EQUIPMENT: The packaged pumping system shall be constructed with Type L cooper headers. Unit shall be rated for 150 PSIG working pressure. Headers shall be easily removable to allow for service access and moving the package through doorways. Pump shall be centrifugal, close-coupled, single stage, end suction type. Pumps shall be rated for a minimum 175 PSIG working pressure. Casings shall have gauge ports and vent and drain ports at top and bottom of casing. Motors shall meet NEMA specifications and shall be of the size, voltage, and enclosure called for on the plans. A globe style, in-line combination pressure reducing and check valve shall be installed on the discharge of each pump. The valve shall have an epoxy coated body with a bronze disk. The valve pilot shall be a direct acting, adjustable, spring-loaded, normally open diaphragm valve. Isolation valves shall be provided for each pump and PRV set. Pressure transducers shall be installed on the suction and discharge headers. Pumps shall be protected from thermal accumulation via a common thermal relief mechanism.

Bell & Gossett



70E DIMENSIONAL DATA

DIMENSIONS - Inches

MODEL NO. 1750 RPM	MODEL NO. 3500 RPM	1531 PUMPS		PRV		A (MAX)	B (MAX)
		LEAD	LAG	LEAD	LAG		
21A	2AA	1-1/4AC	1-1/4AC	1.5	1.5	48.50	49.25
29A	2PA	1-1/4AC	1-1/2AC	1.5	1.5	51.13	54.00
29E	2PE	1-1/4AC	1-1/2AC	1.5	2	51.13	54.00
2JE	2QE	1-1/4AC	2AC	1.5	2	51.38	48.50
2JF	2QF	1-1/4AC	2AC	1.5	2.5	51.38	48.50
2KF	2RF	1-1/4AC	2-1/2AB	1.5	2.5	51.13	48.50
2KG	2RG	1-1/4AC	2-1/2AB	1.5	3	51.13	48.50
22A	2BA	1-1/2AC	1-1/2AC	1.5	1.5	48.50	49.25
22E	2BE	1-1/2AC	1-1/2AC	1.5	2	51.13	54.00
22B	2BB	1-1/2AC	1-1/2AC	2	2	48.50	49.25
23B	2CB	2AC	2AC	2	2	48.50	47.38
23H	2CH	2AC	2AC	2	2.5	51.38	46.75
23C	2CC	2AC	2AC	2.5	2.5	48.50	47.38
24C	2DC	2-1/2AB	2-1/2AB	2.5	2.5	48.50	47.38
24J	2DJ	2-1/2AB	2-1/2AB	2.5	3	51.13	48.38
24D	2DD	2-1/2AB	2-1/2AB	3	3	48.50	47.38
25A	2EA	1-1/4BC	1-1/4BC	1.5	1.5	48.50	49.25
2LA	2SA	1-1/4BC	1-1/2BC	1.5	1.5	53.38	56.63
2LE	2SE	1-1/4BC	1-1/2BC	1.5	2	53.38	56.63
2ME	2TE	1-1/4BC	2BC	1.5	2	52.50	54.75
2MF	2TF	1-1/4BC	2BC	1.5	2.5	52.50	54.75
2NF	2UF	1-1/4BC	2-1/2BB	1.5	2.5	52.63	54.75
2NG	2UG	1-1/4BC	2-1/2BB	1.5	3	52.63	54.75
26A	2FA	1-1/2BC	1-1/2BC	1.5	1.5	48.50	49.25
26E	2FE	1-1/2BC	1-1/2BC	1.5	2	53.75	56.63
26B	2FB	1-1/2BC	1-1/2BC	2	2	48.50	49.25
27B	2GB	2BC	2BC	2	2	48.50	47.38
27H	2GH	2BC	2BC	2	2.5	52.5	49.88
27C	2GC	2BC	2BC	2.5	2.5	48.50	47.38
28C	2HC	2-1/2BB	2-1/2BB	2.5	2.5	48.50	47.38
28J	2HJ	2-1/2BB	2-1/2BB	2.5	3	52.63	49.25
28D	2HD	2-1/2BB	2-1/2BB	3	3	48.50	47.38

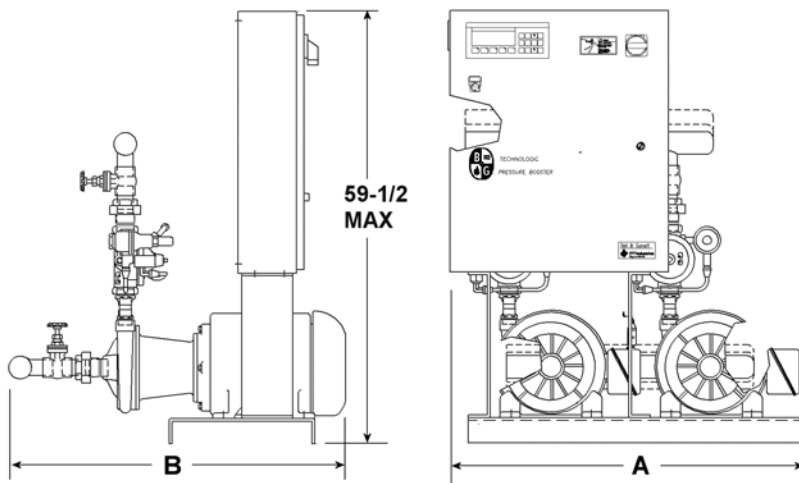

- Panel Included
 Yes
 No
- END CAP LOCATION**
 (Based on facing front panel)
 Both right, as shown
 Both left
 Suction Left, Discharge right
 Suction right, discharge left

Do not use for construction. Dimensions are approximate and subject to change. Contact factory for certified dimensions



Bell & Gossett

Bell & Gossett
 8200 N. Austin Avenue
 Morton Grove, IL 60053
 Phone (847)966-3700
 Facsimile (847)966-9052
 www.bellgossett.com

